

# CAMAR 306 ZÁVRTNÁ NOŽKA

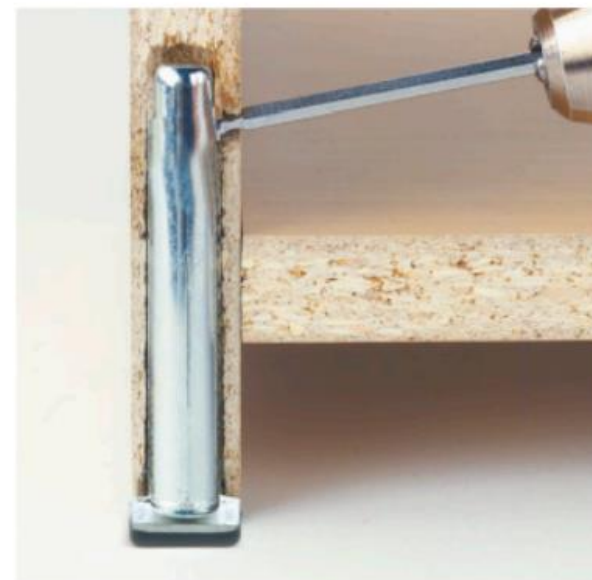
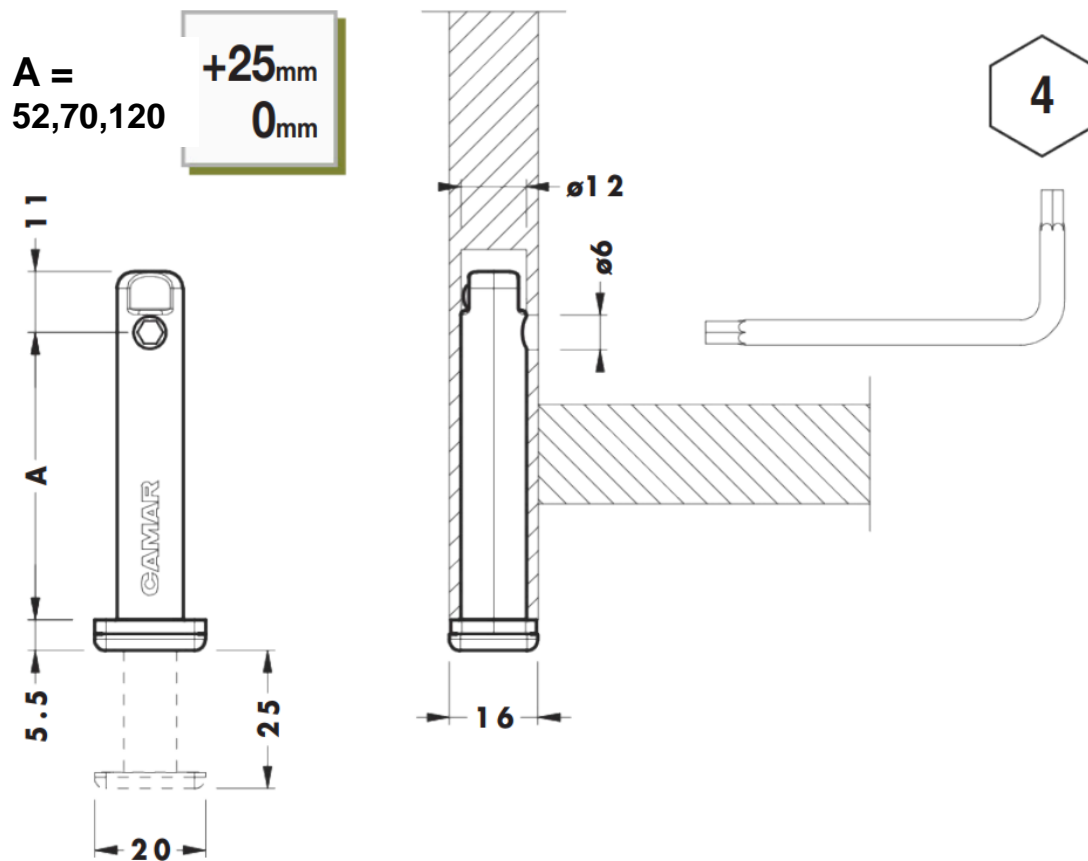

Ø12mm		4	300 Kg	150 Kg
Fe	PP	ZAMAK	LGA	

OBJ.ČÍSLO	ROZMĚRY	MATERIÁL
07.0320.052.02	H52, D12mm	zinek
07.0321.070.02	H70, D12mm	zinek
07.0322.120.02	H120, D12mm	zinek