

MIKROVÝSUVY

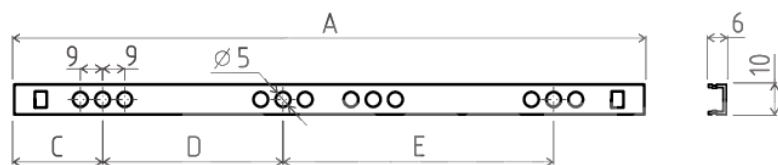

VÝSUV	A	B	C	D	E
190 mm	185	60	18	59	59
220 mm	215	75	18	76	74
250 mm	247	90	18	91	91
280 mm	280	100	18	59	155
310 mm	313	110	18	59	183
340 mm	344	120	18	59	215
350 mm	351	100	27,5	140	140
406 mm	406	100	19	160	192
438 mm	438	100	19	192	192

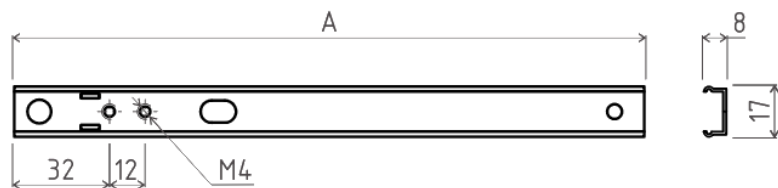
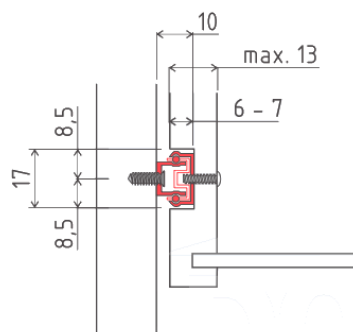
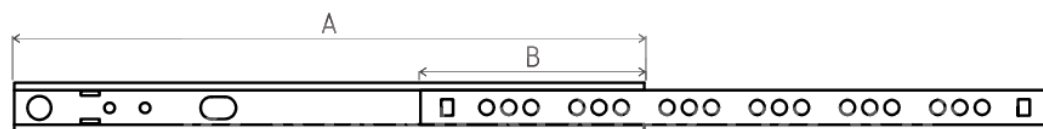

výsuv	délka zásuvky (mm)
190 mm	155 - 200
220 mm	165 - 230
250 mm	185 - 260
280 mm	205 - 290
310 mm	220 - 320
340 mm	255 - 350
350 mm	295 - 360
406 mm	330 - 415
438 mm	360 - 450

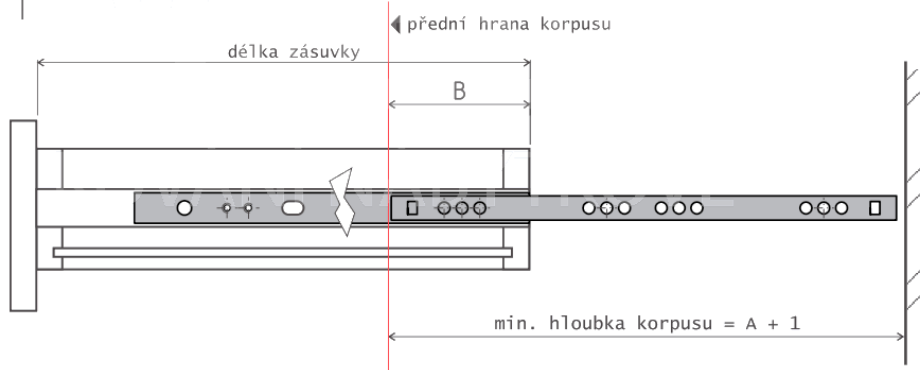
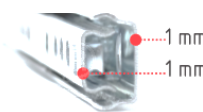

OBJ.ČÍSLO	DÉLKA MM	NOSNOST KG
08.091.019.05	190	10
08.091.022.05	220	10
08.091.025.05	250	10
08.091.028.05	280	10
08.091.031.05	310	10
08.091.034.05	340	10