

Num. articolo	Num. parte	Descrizione	Materiale	Quantità
1	830010_A	Salvasifone	Polistirolo	1
2	830010_B	Adattatore	Polistirolo	2

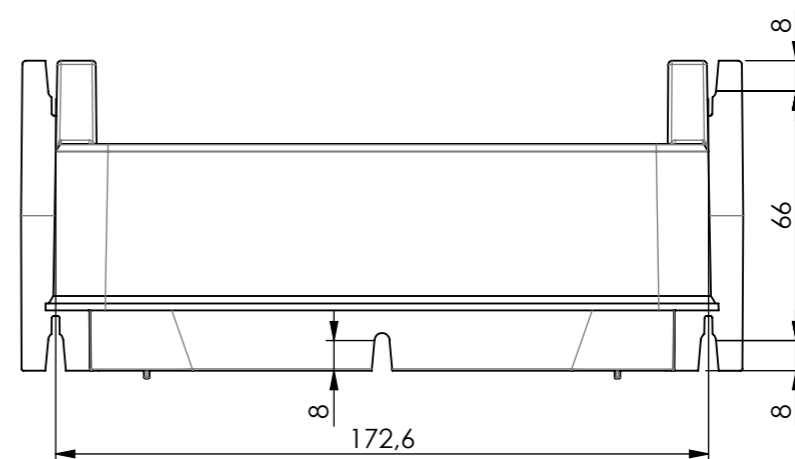
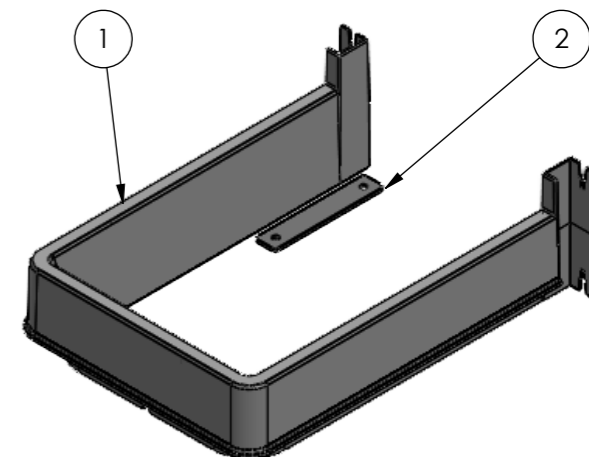

Produkt. Popis
15.0001.6845.56 UNIONPLAST syphon flex - antracit
15.0001.6845.62 UNIONPLAST syphon flex - bílá

unionPLAST SINCE 1976	Codice /code: 830010	Rev. 00	Autore /creator: Federico Benetton	Data /date: 27/02/2024
	Descrizione /description: Salvasifone	Scala /scale: 1:2		
Via della Carrera 4, 31010 Cimadolmo - Treviso - ITALIA	Materiale /material: VEDI TABELLA	Peso [kg] /weight: 0,13	Finitura /finiture: BLACK	
Quote senza indicazione di tolleranza. Grado di precisione Medio UNI EN 22768 - Dimensions without indication of tolerance Degree of precision Medium UNI EN 22768	SMUSSI SENZA QUOTE - CHAMFER NOT QUOTED 0.5X45°	RAGGI SENZA QUOTE - RADIUS NOT QUOTED R=0.5	QUESTO DISEGNO NON PUO' ESSERE RIPRODOTTO O RESO NOTO A TERZI SENZA L'AUTORIZZAZIONE DI UNIONPLAST s.r.l. THIS DRAWING MAY NOT BE COPIED OR PASSED TO A THIRD PARTY WITHOUT PERMISSION BY UNIONPLAST s.r.l.	