

**INOXA GOLD POTR. SKŘÍŇ 300 a 400 mm**

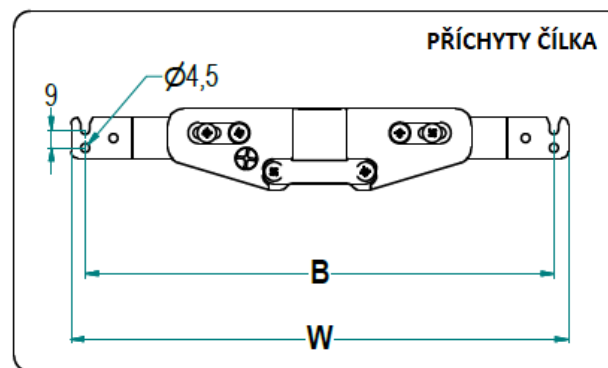

Korpus L (mm)	W (mm)	B (mm)
300	246	232
400	346	332

Korpus L (mm)	W (mm)
300	240
400	325

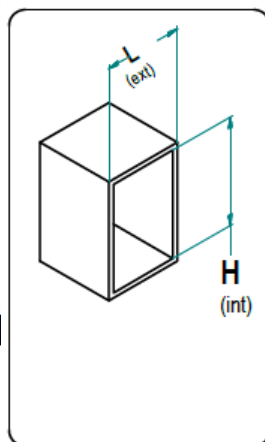
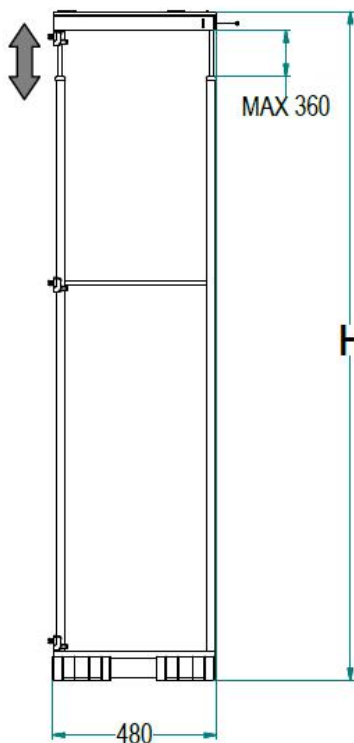
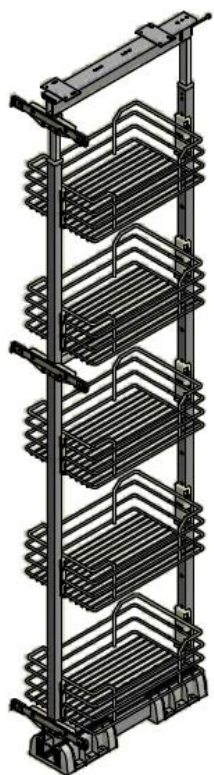
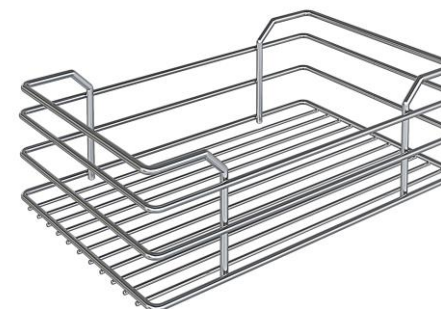
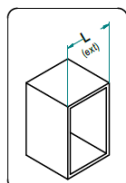
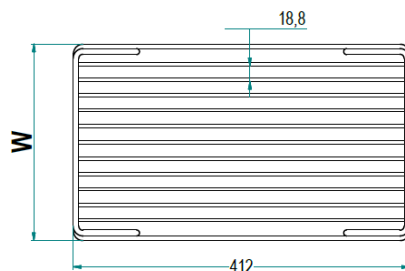
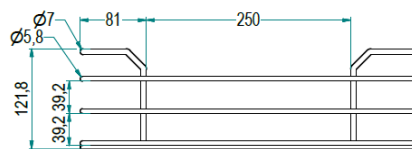
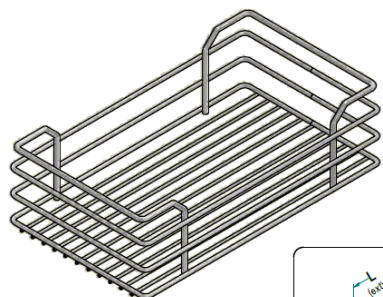

obj.č.	do korpusu (mm)	Výška min-max	Počet košů	spec.	výsuv
H25.4630.10	300	1835-2185	5	drátěné dno	100% s tlum
H25.4640.10	400	1835-2185	5	drátěné dno	100% s tlum