

**INOXA LAHVOVNÍK ELLITE 150 a 200**

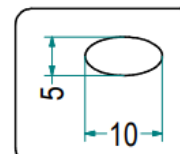

OVÁLNÝ DRÁT

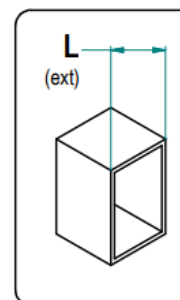
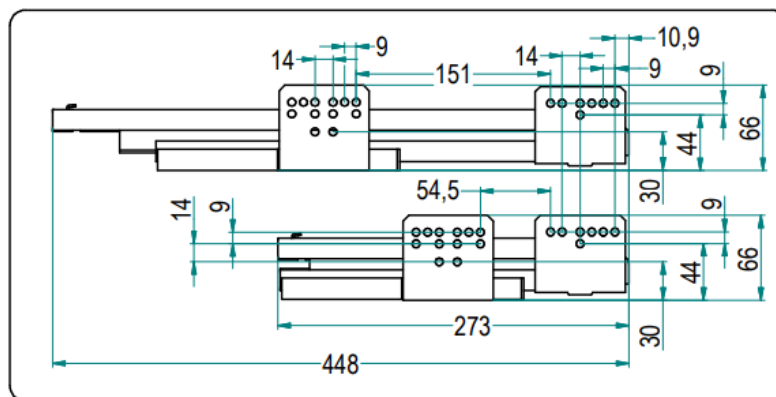
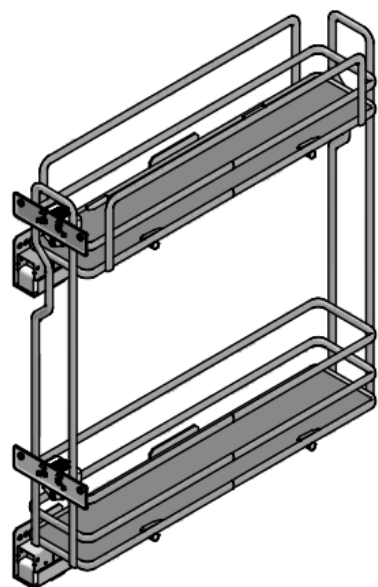
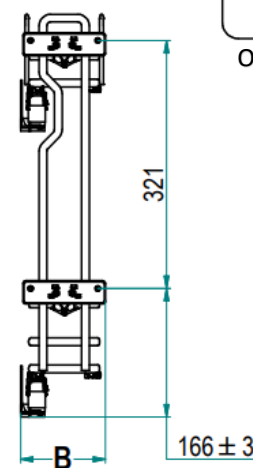
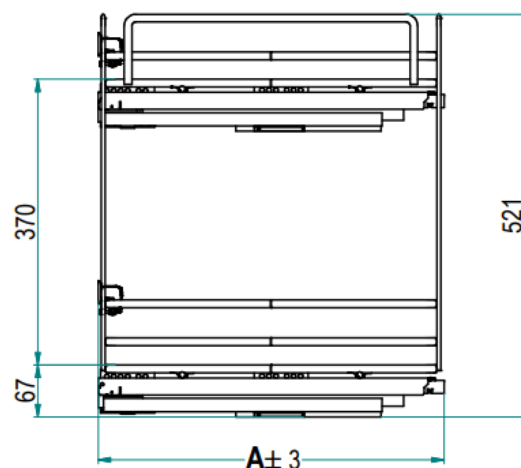
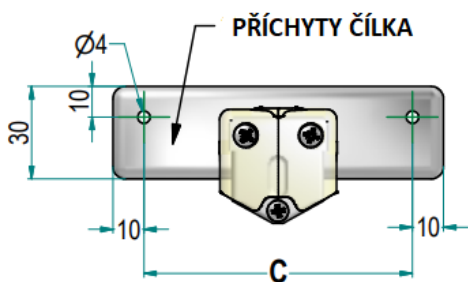

obj.č.	šířka (mm)	délka (mm)	orientace	povrchová úprava	výsuv
H29.1015.10	150	500	L	chrom/bílá	100% s tlum, Grass
H29.1015.57	150	500	L	titán/antracit	100% s tlum, Grass
H29.2015.10	150	500	P	chrom/bílá	100% s tlum, Grass
H29.2015.57	150	500	P	titán/antracit	100% s tlum, Grass
H29.1020.10	200	500	L	chrom/bílá	100% s tlum, Grass
H29.1020.57	200	500	L	titán/antracit	100% s tlum, Grass
H29.2020.10	200	500	P	chrom/bílá	100% s tlum, Grass
H29.2020.57	200	500	P	titán/antracit	100% s tlum, Grass

Korpus L (mm)	A (mm)	B (mm)	C (mm)
150	451	110	87
200	451	160	137

\*verze s výsuvem vlevo, montáž vpravo je založená na stejné logice a rozměrech